

**-GENERAL NOTES-**

1. This drawing is not to be scaled.
2. Figured dimensions only are to be taken from this drawing.
3. All setting out dimensions are to be checked and confirmed on site prior to commencement of work.
4. Any discrepancies encountered to be brought to the attention Medite Europe DAC without delay.
5. For Planning Purposes Only

**-NOTES-**

- KEY PLAN**
- EXISTING INFRASTRUCTURE**
- 1.1 SOUTHERN SITE ENTRANCE
  - 1.2 NORTHERN SITE ENTRANCE
  - 1.3 WAREHOUSE / OFFICE & STORES
  - 1.4 PRODUCTION LINE 1 AREA
  - 1.5 PRODUCTION LINE 2 AREA
  - 1.6 LINE 1 WOOD BIOMASS FIRED BOILERS
  - 1.7 LINE 1 DRYERS BUILDING
  - 1.8 LINE 2 DRYER
  - 1.9 LINE 2 WOOD BIOMASS FIRED THERMAL FLUID HEATER
  - 1.10 DE-BARKER BUILDING
  - 1.10A DE-BARKER INFED CONVEYOR
  - 1.11 OUTDOOR FUEL STORAGE / FUEL SHED
  - 1.12 CHIP STORAGE / YARD
  - 1.13 CLASS-CLEANER
  - 1.14 SURFACE WATER MANAGEMENT LAGOONS
  - 1.15 CHEMICAL STORAGE BUILDING
  - 1.16 WASTE WATER TREATMENT PLANT (WWTP)
  - 1.17 WATER STORAGE PONDS
  - 1.18 CAR PARK
  - 1.19 MIX BUILDING
  - 1.20 SUBSTATION
  - 1.21 LOG STORAGE AREAS
  - 1.22 TRUCK TIPPER
  - 1.23 REFINER BUILDING
  - 1.24 CHIP STORAGE SILOS
  - 1.25 LINE 1 GAS FIRED THERMAL FLUID HEATER
  - 1.26 EDGE TRIM SILO
  - 1.27 LINE 1 SANDER DUST SILOS
  - 1.28 LINE 1 FIBER HANDLING BUILDING
  - 1.29 FINISHED GOODS WAREHOUSE

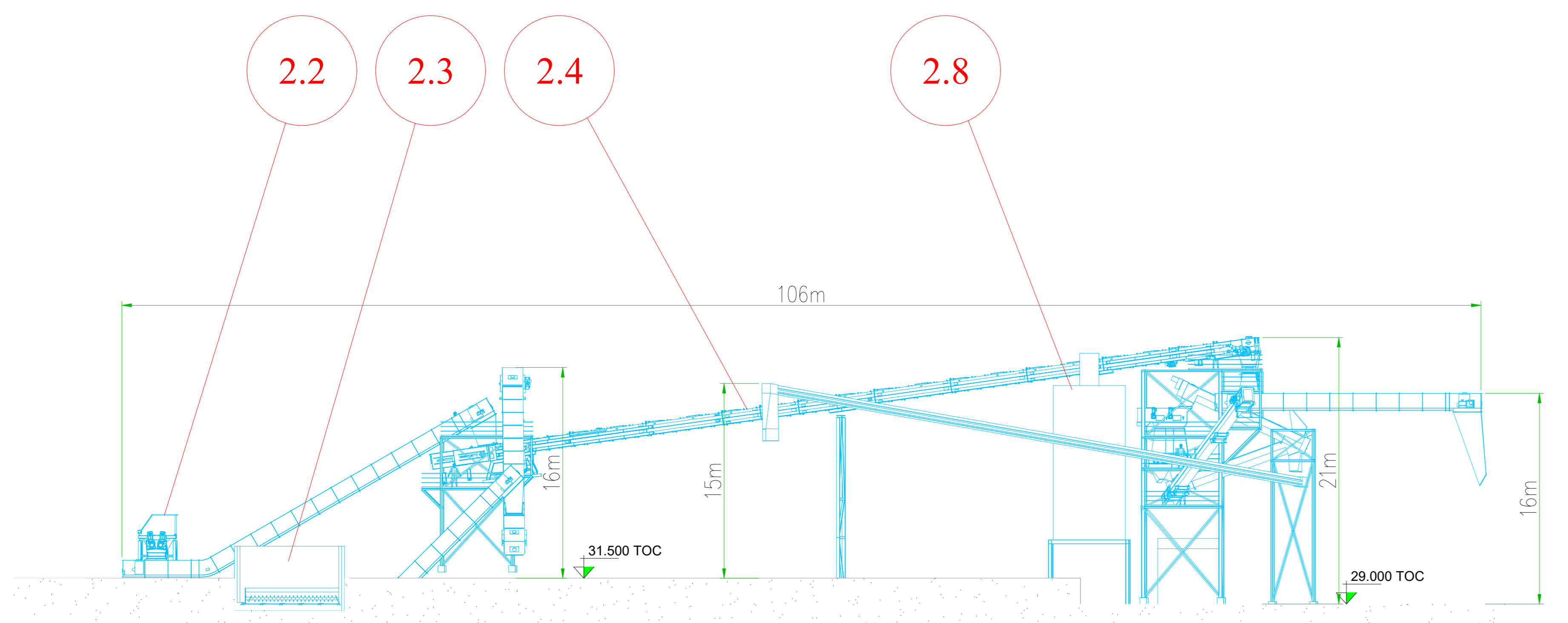

Section A-A

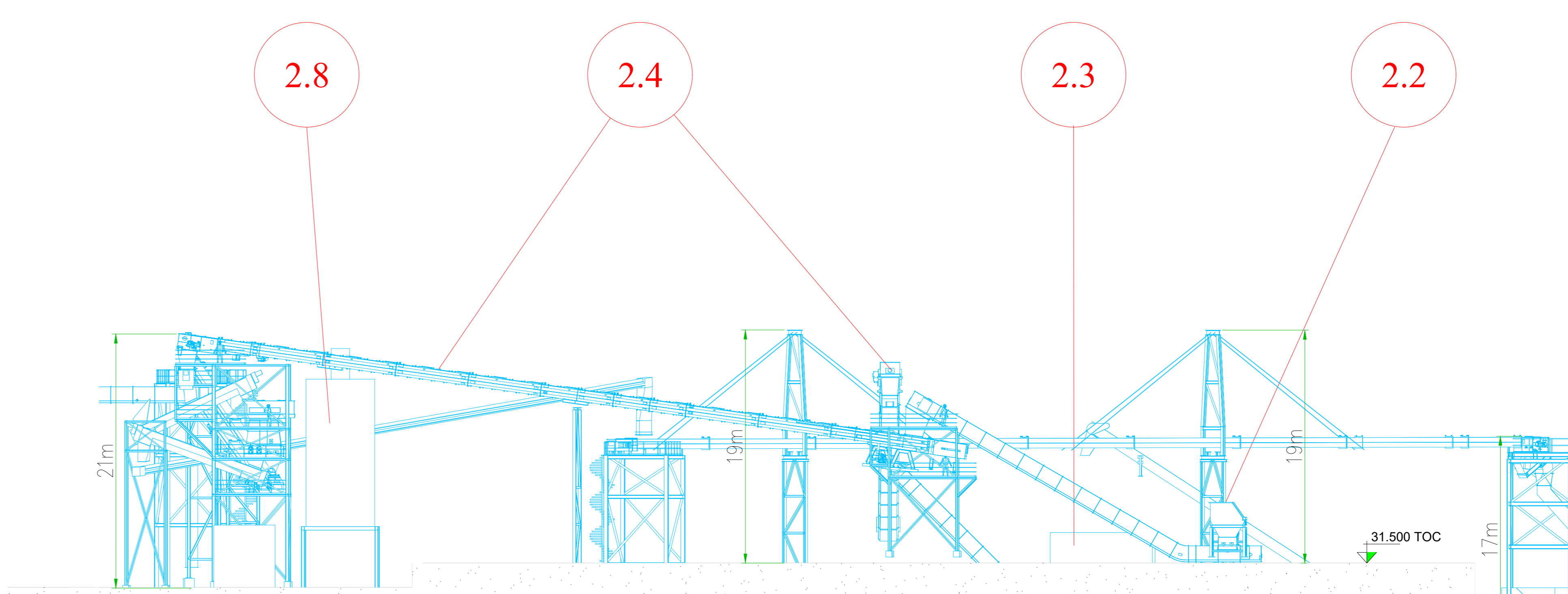

Section B-B

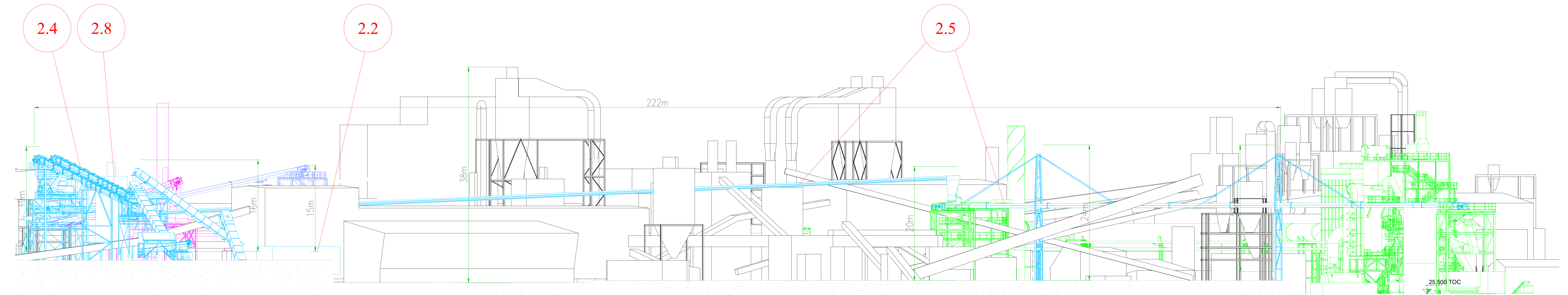

Section C-C

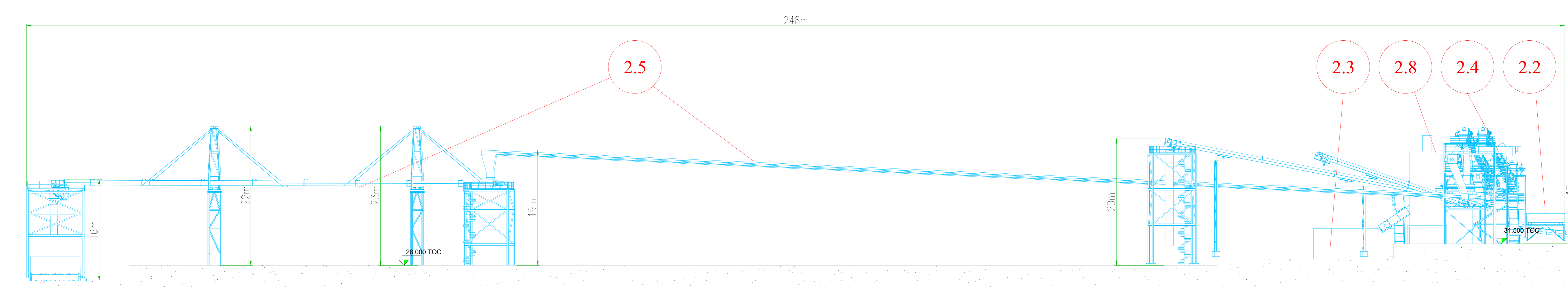

Section D-D

- PROPOSED DEVELOPMENT**
- DEVELOPMENT AREA 1**
- 2.1 FUEL RECEPTION UNITS
  - 2.2 FUEL INFED HOPPER
  - 2.3 WALKING FLOOR INFED SYSTEM
  - 2.4 CONVEYING SYSTEM #1
  - 2.5 CONVEYING SYSTEM #2 (to Line 1 Energy Plant)
  - 2.6 CONVEYING SYSTEM #2 (to Line 2 Energy Plant)
  - 2.7 PNEUMATIC (DRY FUEL) SYSTEM
  - 2.8 EDGE TRIM SILO
- DEVELOPMENT AREA 2**
- 3.1 LINE 1 WET FUEL METERING BIN
  - 3.2 LINE 1 ENERGY SYSTEM FUEL FEED CONVEYOR
  - 3.3 LINE 1 ENERGY PLANT
  - 3.4 LINE 1 DRY ELECTROSTATIC PRECIPITATOR
  - 3.5 LINE 1 HOT GAS DUCT
  - 3.6 LINE 1 START UP STACK
  - 3.7 LINE 1 DUST SILO
  - 3.8 LINE 1 THERMAL FLUID PIPING
  - 3.9 LINE 1 STEAM GENERATOR
- DEVELOPMENT AREA 3**
- 4.1 LINE 2 ENERGY PLANT
  - 4.2 LINE 2 DRY ELECTROSTATIC PRECIPITATOR
  - 4.3 LINE 2 HOT GAS DUCT
  - 4.4 LINE 2 START UP STACK
  - 4.5 LINE 2 THERMAL FLUID PIPING

**SLR**  
SLR CONSULTING IRELAND  
7 DUNDURAM BUSINESS PARK  
WINDY ARBOUR  
DUBLIN 14  
T: +353-1-2964657  
F: +353-1-2964656  
www.slrconsulting.com

STAGE	REV	REVISION NOTE	DATE	SNL

Project File: Replacement of Existing Energy Systems

Project Code: Medite Europe DAC  
Killeshin, Co. Wick, Tipperary

File: Development Area 1  
Proposed Sections

Machine	Site	Plant	Process	Machine	Sub-Machine
01 - 00 - 700 - 000 - 00					

Fig. Number	Description	Date	Drawn By	Approved By
700		29/09/2023	S. Murphy	M. O'Neil/Kathleen

Scale: 1:250 @ A3 Date: 29/09/2023 Drawn By: S. Murphy Approval By: M. O'Neil/Kathleen  
Drawing Number: ABP-311991-21.PL1.I-1 Rev: 01

